

Iskutilavuus / Stroke volume 51,2 dm<sup>3</sup>.

Max. paine / pressure 250 bar (25 MPa).

Max. kuorma / load 32 t.

\*Asennusvara / Recommended mounting space min. 15 mm.

Tiivistesarja / Seal kit: 340209016

TELS / TELC: 310207336

M\* = Lavakiinnikkeen pohjaan/To the bottom of the body bracket.  
 N\* = Lavakiinnikkeen pohjasta z-palkin pohjaan/  
 From the bottom of the body bracket to the bottom of the z-beam.

Tarkemmat asennusmitat piirustuksesta 300209200/  
 More detailed mounting dimension on drawing 300209200

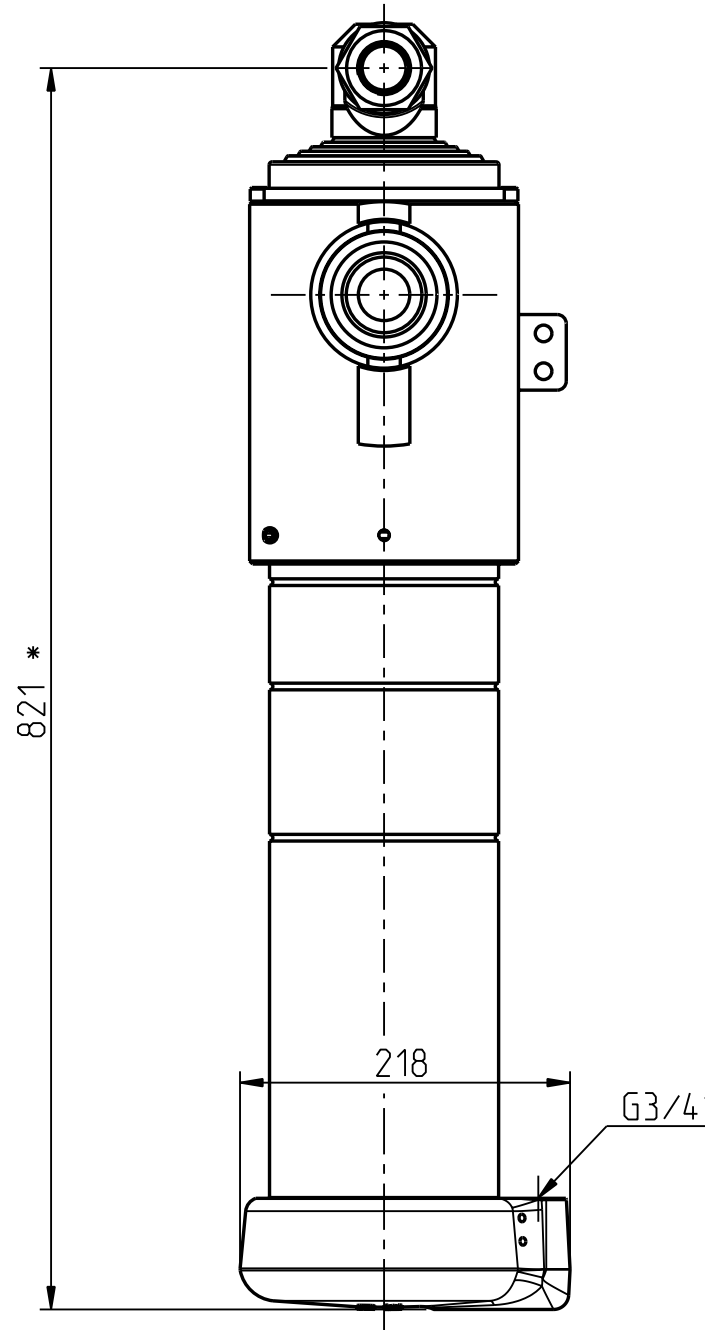

Dim.	Stroke
Ø132	580
Ø115	586
Ø100	586
Ø85	586
Ø70	588
Ø55	594
Tot.	3520

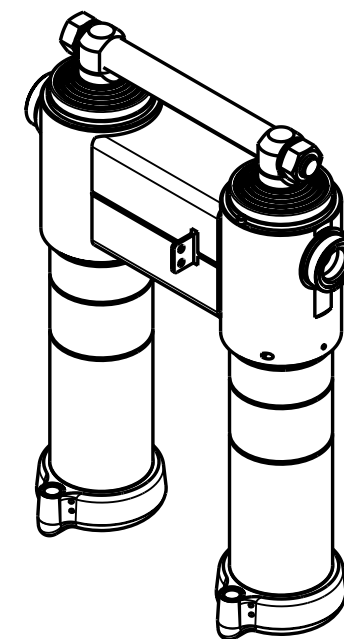

23.03.17	TDa	a1) Oli ennen/was before 160 (ryhmäkotelo vaihdettu/ram case changed).		
Date	Drawn	Revision		
	Piirt Drawn	JMe	GENERAL TOLERANCE : ISO 2768-m	Koodi Code -
	Pvm Date	20.11.09	THREAD TOLERANCE : ISO 965-3/ISO 228-1	Paino (kg) Weight 211.860
	Koko Size	A3	WELD ACCORDING TO: ISO 5817	Material STD -
Liittyy / Belongs to				Material
RT59				-
Nimitys				Suhde/Scale
SRYHMÄ 152/55x3520 (DA24)				1:5
Name				Revision
CYL GR 152/55x3520 (DA24)				A
				Piirustus no / Drawing no
				310207309

