

M* = Lavakiinnikkeen pohjaan/To the bottom of the body bracket.
 N* = Lavakiinnikkeen pohjasta z-palkin pohjaan/
 From the bottom of the body bracket to the bottom of the z-beam.

Tarkemmat asennusmitat piirustuksesta 300209200/
 More detailed mounting dimension on drawing 300209200

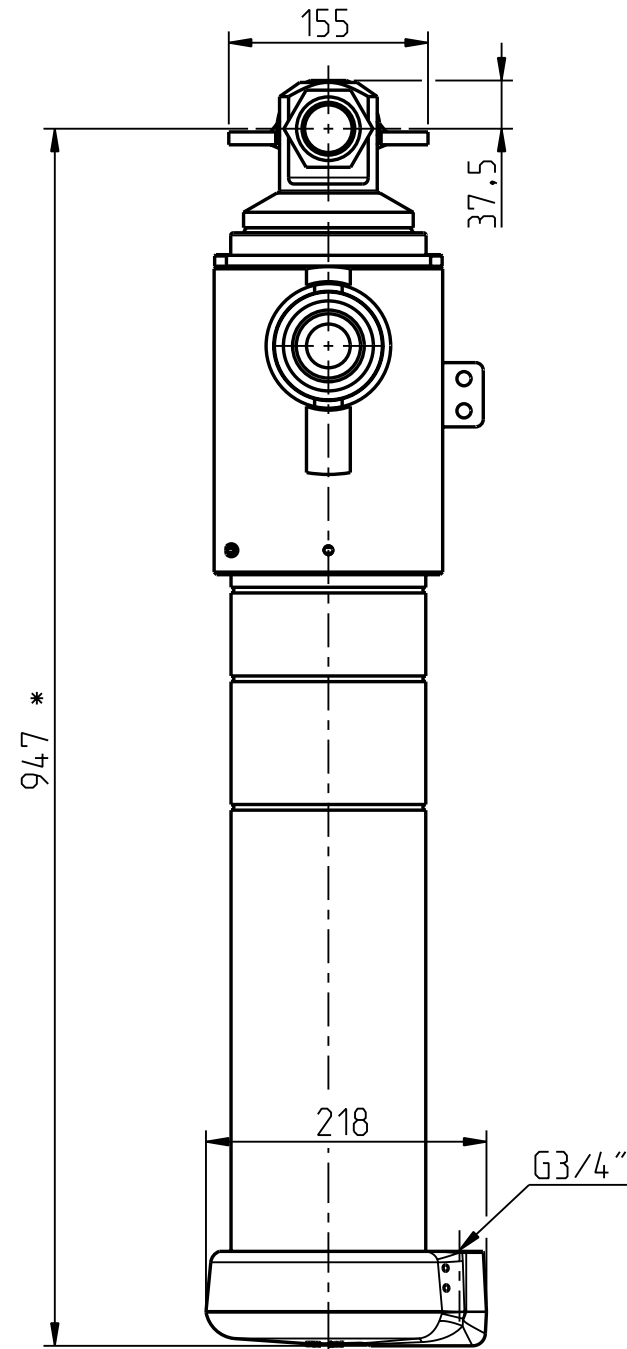

Dim.	Stroke
Ø132	686
Ø115	695
Ø100	690
Ø85	690
Ø70	690
Ø55	712
Tot.	4163

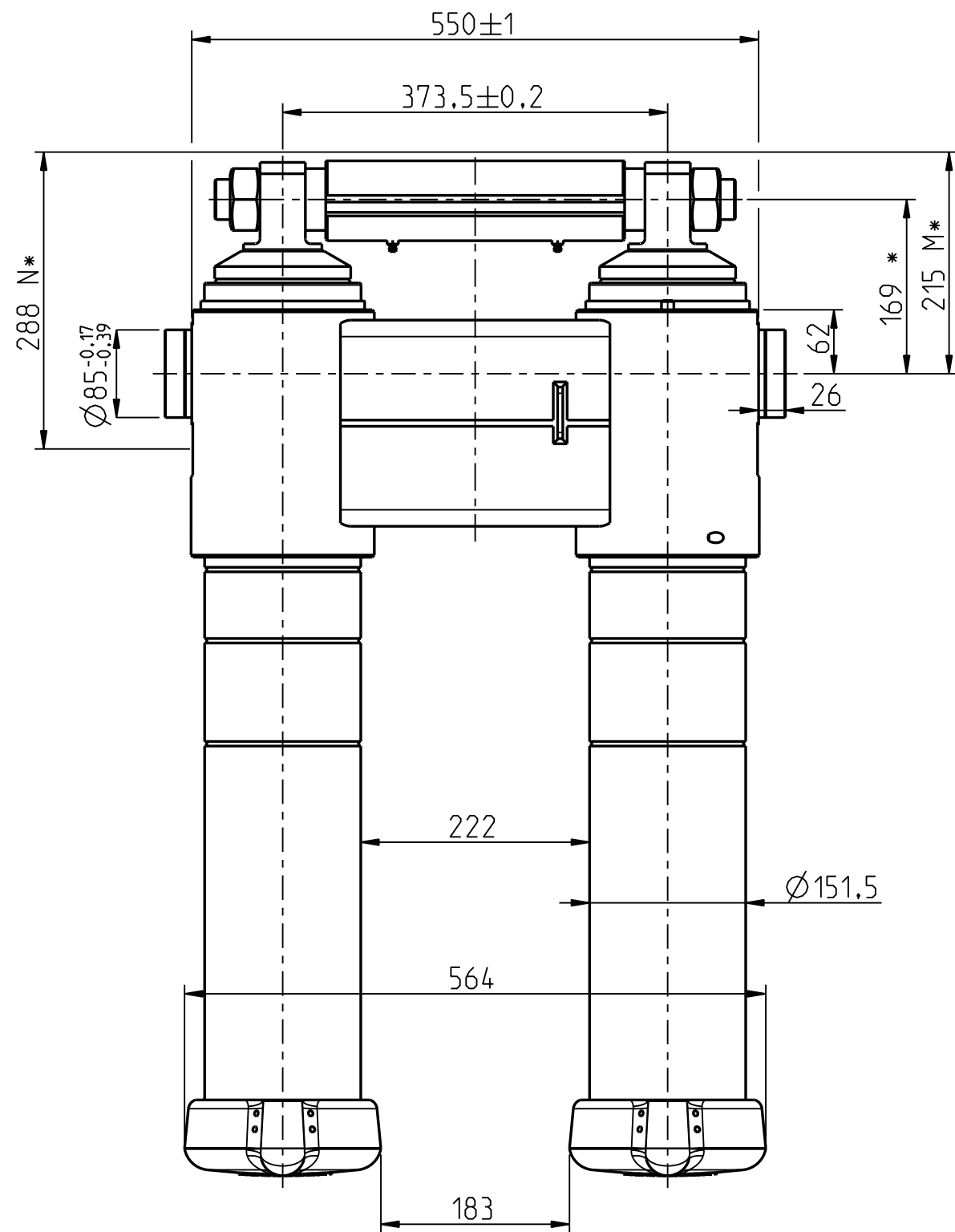
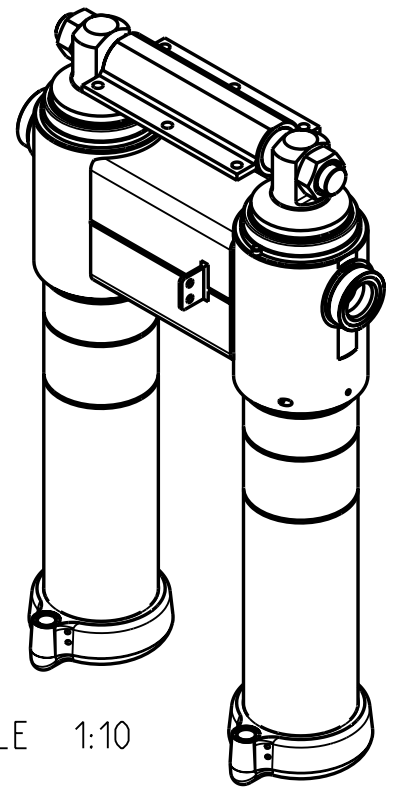

Iskutilavuus / Stroke volume 60.6 dm³

Max. paine / pressure 250 bar (25 MPa)

Max. kuorma / load 50 t

* Asennusvara / Recommended mounting space min. 15 mm

Tiivistesarja / Seal kit: 340209016

Date	Drawn	Revision		
		Piirt Drawn	TDa	GENERAL TOLERANCE : ISO 2768-m
		Pvm Date	23.12.16	THREAD TOLERANCE : ISO 965-3/ISO 228-1
		Koko Size	A3	WELD ACCORDING TO: ISO 5817
Liittyy / Belongs to			RT70 50†	
Nimitys			SRYHMÄ 152/ 55x4163 (DA24)	Suhde/Scale
Name			CYL GR 152/ 55x4163 (DA24)	Revision
				17:100
				-
			Piirustus no / Drawing no	
			310208887	