

M* = Lavakiinnikkeen pohjaan/To the bottom of the body bracket.
 N* = Lavakiinnikkeen pohjasta z-palkin pohjaan/
 From the bottom of the body bracket to the bottom of the z-beam.

Tarkemmat asennusmitat piirustuksesta 300209200/
 More detailed mounting dimension on drawing 300209200

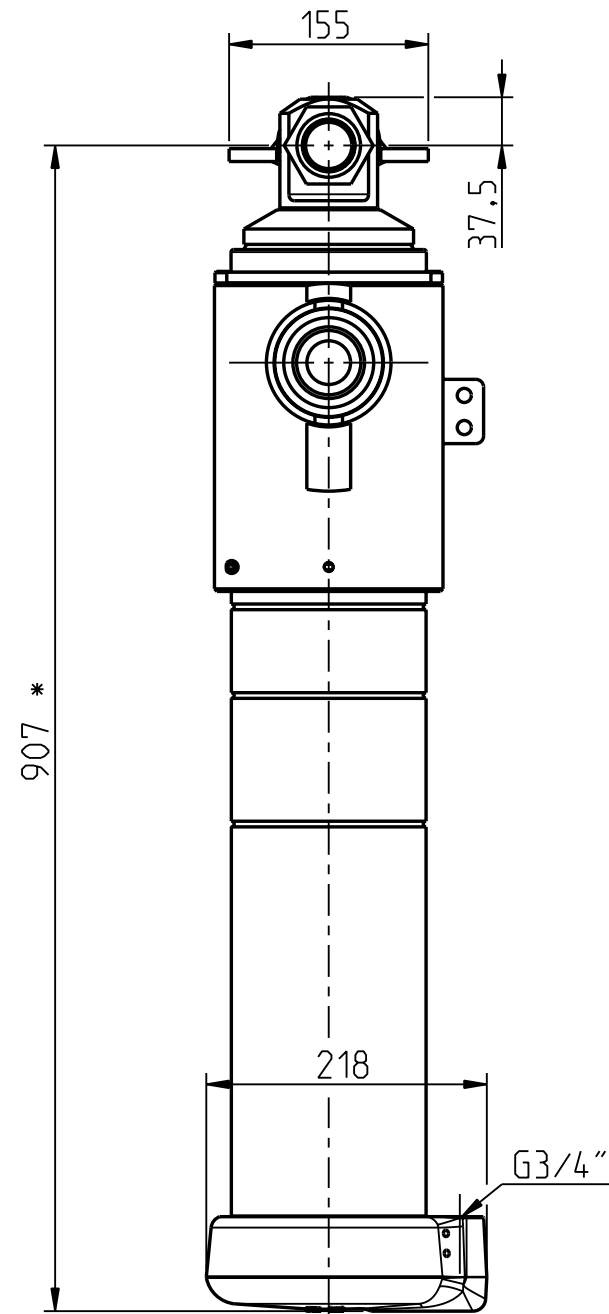

Dim.	Stroke
Ø132	647
Ø115	655
Ø100	650
Ø85	650
Ø70	650
Ø55	673
Tot.	3925

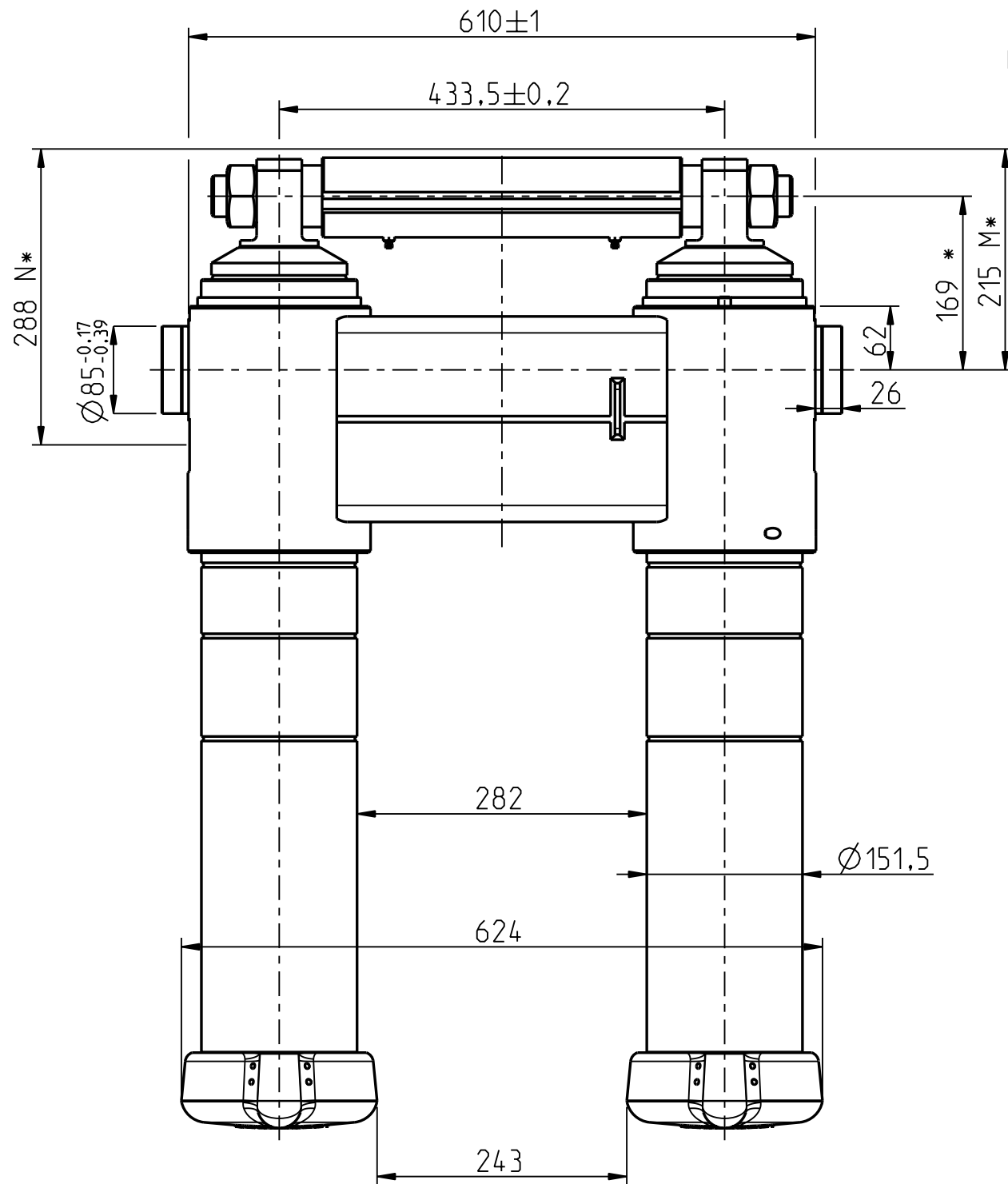
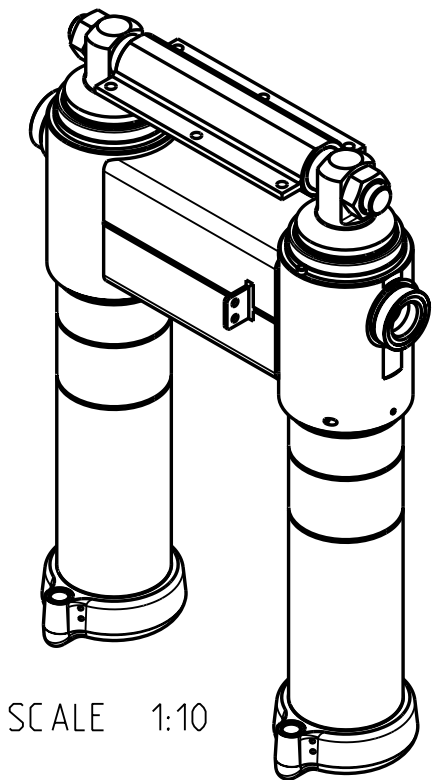

Iskutilavuus / Stroke volume 57.2 dm³

Max. paine / pressure 250 bar (25 MPa)
 Max. kuorma / load 50 t

* Asennusvara / Recommended mounting space min. 15 mm

Tiivistesarja / Seal kit: 340209016
 TELS / TELC: 310207342

Date	Drawn	Revision		
		Piirt Drawn	TDa	GENERAL TOLERANCE : ISO 2768-m
		Pvm Date	23.12.16	THREAD TOLERANCE : ISO 965-3/ISO 228-1
		Koko Size	A3	WELD ACCORDING TO: ISO 5817
		Liittyy / Belongs to		Material
		RTW66 50t		-
		Nimitys	SRYHMÄ 152/55x3925 (DA24)	Suhde/Scale
		Name	CYL GR 152/55x3925 (DA24)	Revision
				17:100
				-
				Piirustus no / Drawing no
				310209081